



Agricultural Chemical Storage and Containment

DRY FERTILIZER DUST PROTECTION ATCP 33.62

Wis. Admin. Code § ATCP 33.62 requires that dry bulk load out systems must be equipped with a loading chute or other dust control device such that the air-gap between the end of the chute and the “top rim” of vehicle being loaded is no more than 2 feet. Questions have arisen as to how this can be accomplished with existing conveyor load-outs. This is a potential solution.



Although this set-up is on the bottom of a tower blender, the concept should be transferable to virtually any load-out. The “box” to which the “sock” is attached does not necessarily need to be as tall as shown.

Here is a drawn example of how such a set-up could be used. The black dot is intended to denote the hinge around which the “box” can be moved out of the way for truck loading.

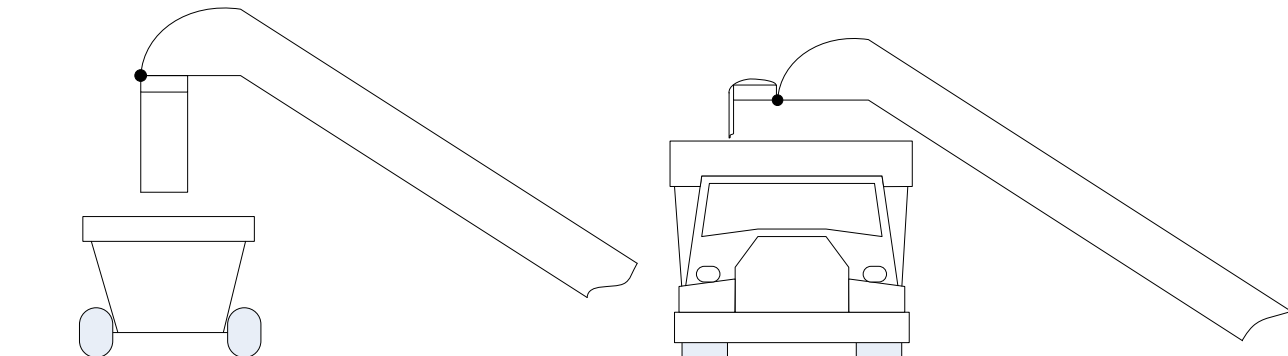

Wisconsin - America's Dairyland

2811 Agriculture Drive • PO Box 8911 • Madison, WI 53708-8911 • Wisconsin.gov

An equal opportunity employer